

AGENDA

LODGING TAX ADVISORY COMMITTEE

July 9, 2025

Hybrid Meeting In-person and via Zoom



Accessibility

The City of Ellensburg strives to make our services, programs, and activities readily accessible.

- Closed Captioning is available to Zoom viewers. To enable closed captioning, you will need to click on the "CC" button at the bottom of your Zoom screen and then select either "Show Subtitle" or "View Full Transcript."
- Members of the public who do not speak English or who have limited proficiency may request an interpreter if they wish to participate in public meetings.
 - The City will provide reasonable accommodation for members of the public with disabilities.

Please submit requests for language assistance or reasonable accommodation to the HR Director/ADA Coordinator by calling (509) 962-7222 or by email at ADACoordinator@ellensburgwa.gov. Five (5) business days' notice is appreciated.

**CITY OF ELLENSBURG
LODGING TAX ADVISORY COMMITTEE AGENDA**

**Council Conference Room
501 North Anderson Street
Ellensburg, WA 98926
And remotely via Zoom
Wednesday, July 9, 2025
2:00 PM - Regular Meeting
Join Zoom**

Meeting <https://us02web.zoom.us/j/81974352810?pwd=oVKaTjdjbcAw4Ay5V3BbKHcAajTLNZ.1&from=addon>

**Meeting ID: 872 9297 1205
Passcode: 247907**

- 1. Call to Order and Roll Call of Members**
 - 1.A ROLL CALL: Council Member Beauchamp, Committee Member Dawson, Committee Member Evasick, Committee Member Fortier, Committee Member Townsend, Committee Member Wiggins
- 2. Approval of Agenda**
 - 2.A Review and Approval of Lodging Tax Advisory Committee July 9, 2025 meeting agenda
- 3. Approval of Minutes**
 - 3.A Review and approval of Lodging Tax Advisory Committee May 7, 2025 meeting minutes
- 4. Budget Update**
 - 4.A Revenue and Expense Update
- 5. New Business**
 - 5.A Letter from Consolidated Lodging Tax Advisory Committee
- 6. Unfinished Business**
 - 6.A Downtown Trash Can Replacement Review and Recommendation
 - 6.B Community Calendar
- 7. Kittitas County Chamber of Commerce Tourism Report & Update**
 - 7.A Tourism Report
- 8. Citizen Comment**
- 9. Adjournment**



For more information on the Ellensburg Lodging Tax Advisory Committee, contact Arts & Economic Development Manager, Kelle Vandenberg at 509-962-7149.
The Contents of this agenda have been photocopied on recycled paper.



CITY OF ELLENSBURG

Minutes of Lodging Tax Advisory Committee, Regular Meeting

Date of Meeting

May 7, 2025

Time of Meeting

2:10 PM

Place of Meeting

Council Conference Room 501 North Anderson Street

Ellensburg, WA 98926

And remotely via Zoom

1. Call to Order and Roll Call

1.A Roll Call Present: Sarah Beauchamp, Carmen Wiggins, Steve Townsend, Arlo Evasick

Absent: Gemma Fortier, Lacie Dawson,

Guests: Matt Anderson, Kittitas County Chamber of Commerce, Amy McGuffin, CEO Kittitas County Chamber of Commerce

2. Approval of Agenda

2.A Motion: Move to amend the May 7, 2025, LTAC agenda to include Item 6.A To Review and Update Committee Schedule for 2025 and moving Introduction of the Downtown Ellensburg Beautification Report to item 6.B under New Business.

By: Carmen Wiggins

Seconded by: Sarah Beauchamp

All in Favor:

Opposed: None

Abstained: None

Motion carries

2.B Motion: Move to approve the May 7, 2025, LTAC agenda with the aforementioned amendment to the agenda as presented.

By: Carmen Wiggins

Seconded by: Sarah Beauchamp

All in Favor:

Opposed: None

Abstained: None

Motion carries

3. Approval of Minutes

3.A Approval of March 5, 2025, Lodging Tax Advisory Committee meeting minutes.

Motion: Move to approve March 5, 2025, Lodging Tax Advisory Committee meeting minutes.

By: Steve Townsend

Seconded: Arlo Evasick
All in Favor: All in Favor
Opposed: None
Abstained: None
Motion Carries

4. Budget Update

3.A Staff reviewed current LTAC budget: expenses and revenues.

Staff Action Item: Review budget for accuracy with regards to Beginning Fund Balance send back out to committee with draft of meeting minutes.

5. Unfinished Business

5.A Community Calendar Discussion and Action.

Staff reviewed the community calendar project with committee members. The company, "With" Community Calendar offers an exclusive platform utilizing API technology to seamlessly connect multiple calendars across several unconnected platforms. "With" offers a unique service with proprietary systems. There was discussion regarding interfacing capacity with MyEllensburg.com and the following:

- i. Payment feature presented in the service agreement would not be utilized, as all organizations hosting events already had payment processing system.
- ii. Year one service agreement is for \$10,000+ taxes etc., this includes initial installation and setup, what will be year two costs and beyond?

The questions above the committee felt were easily addressed through the contracting process and would not hold up their recommendation to council.

Motion: Move to recommend for council approval for city staff to hire and engage the services of "With" Community Calendar and utilize up to \$12,000.00 of LTAC funds to create a comprehensive community calendar to enhance transparency of community events and increase tourism.

By: Steve Townsend
Seconded: Arlo Evasick
All in favor: All
Opposed: None
Abstained: None
Motion carries

Staff Note and Action: Staff will prepare a report and present LTAC recommendation to City Council at the June 2nd council meeting for review.

Sarah Beauchamp left room for phone call. Quorum stopped at 2:35 pm. Resumed at 2:36pm.

6. New Business

6.A Update/Adjust schedule to monthly

Motion: Move to update committee schedule from every other month to monthly meetings effective beginning in June.

By: Carmen Wiggins

Seconded: Steve Townsend

All in favor: All

Opposed: None

Abstained: None

Motion carries

2025 LTAC Schedule as followings:

Wednesday, June 4th at 2:00 pm

Wednesday, July 9th at 2:00 pm

Wednesday, Aug. 6th at 2:00 pm

Wednesday, Sept. 10th at 2:00 pm

Wednesday, Oct. 1st at 2:00 pm

Wednesday, Nov. 5th, at 2:00 pm

Wednesday, Dec. 3rd at 2:00 pm

Staff Action Item:

1. Cancel/update all existing calendar invites/Zoom links.
2. Send individual calendar invites w/same Zoom link.
3. Update LTAC page on City website

Carmen Wiggins stepped out to take a call at 2:47 pm. Meeting paused. Meeting resumed at 2:49 pm.

6.B Draft Introduction of the Downtown Ellensburg Beautification Report

This report is in partnership with city staff and the Ellensburg Downtown Association.

Staff introduced a draft of the Downtown Ellensburg Beautification Report and discussed the challenges of existing trash cans and planters within the downtown, noting that the trash cans are at a high priority, critical need stage.

Staff reviewed estimated quote from EDA to repair existing trash cans. Capacity of existing cans was discussed by committee members and staff. City staff and EDA are reviewing replacement options that will be visually appealing, offer a high capacity of use, and be longer lasting and durable to the harsh climate conditions and wind.

Existing trash cans were purchased through LTAC funded recommendation to City Council.

Staff Action Item: For June LTAC meeting, staff will prepare and present three options for replacement to committee for review and estimated pricing comparison.

7. Kittitas County Chamber of Commerce: Marketing/Tourism Report

7.A Kittitas County Chamber of Commerce Marketing/Tourism Report, as presented by CEO, Amy McGuffin.

Since hiring a content manager, all social media engagement is up significantly. Social media reports will be presented monthly by the Kittitas County Chamber of Commerce, with larger tourism report being presented quarterly.

7.B LTAC Grants and Funding Update: Timeline/Process for 2026 Applications

July 1, 2025: Application period will open

August 2025: Application Workshops will be offered by Chamber

Sept. 30, 2025: Application period will close

October 2025: Lodging tax committees will review and score applications individually, and committees will have group meeting to finalize and score applications, staff will submit to county.

Nov.-Dec. 2025: CLTAC 2026 Applicant Presentations and Scoring for final award. Date is TBD.

8. Citizen Comment

No citizen comment to report.

9. Adjournment

With no further business, the meeting was adjourned at 3:30 pm.

Respectfully Submitted,
Kelle Vandenberg

2025 Budget Expenditures

TENTATIVE RESERVES - END OF 2024

| | | | |
|--|----------------------------|-------------------|---------------|
| Projected 2025 Revenues | Dept 165- Lodging Tax Fund | Beg. Fund Balance | Revenues YTD |
| EOY Balance incl. projected expenditures | Updated: 05/15/25 | \$ 1,634,549.00 | \$ 149,941.00 |

| Fund # | Description | Appropriated | Disbursed thru 2025(PAID OUT) | Remaining | |
|---------------------------|---|--------------|----------------------------------|--------------|--|
| 100-165-557-31-51-000-000 | CLTAC Grant Funding | \$ 97,595.29 | | \$ 97,595.29 | CHAMBER 2025 |
| reimburse Kittitas County | | | | - | \$ 324,600.00 |
| Ellensburg | Gallery One | \$ 5,205.92 | \$ 5,205.92 | 5,205.92 | Includes amended contract VIC at Unity Park May-Sept. |
| Cle Elum | Cle Elum Downtown Association | \$ 5,205.92 | \$ 5,205.92 | 5,205.92 | |
| Kittitas County | Washington State Ski & Snowboard Museum | \$ 3,123.55 | \$ 3,123.55 | 3,123.55 | |
| Ellensburg | Kittitas County Historical Society | \$ 3,581.67 | \$ 3,581.67 | 3,581.67 | |
| Roslyn | Roslyn Ronald Cle Elum Heritage Club | \$ 4,581.21 | \$ 4,581.21 | 4,581.21 | |
| Ellensburg | Ellensburg Downtown Association | \$ 7,236.23 | \$ 7,236.23 | 7,236.23 | |
| Ellensburg | Ellensburg Music Festival | \$ 4,581.21 | \$ 4,581.21 | 4,581.21 | |
| Roslyn | Roslyn Downtown Association | \$ 6,663.58 | \$ 6,663.58 | 6,663.58 | |
| | Webb Events | \$ 15,617.76 | \$ 15,617.76 | 15,617.76 | |
| Cle Elum | International Lumber Jack Show | \$ 10,411.84 | \$ 10,411.84 | 10,411.84 | |
| Ellensburg | Junk Tiquen in the Burg | \$ 1,648.30 | \$ 1,648.30 | 1,648.30 | |
| Ellensburg | Ellensburg Rodeo Hall of Fame | \$ 7,288.29 | \$ 7,288.29 | 7,288.29 | |
| Cle Elum | Cle Elum Roundup Association | \$ 3,687.87 | \$ 3,687.87 | 3,687.87 | |
| Ellensburg | Laughing Horse Arts Foundation | \$ 853.56 | \$ 853.56 | 853.56 | |
| Thorp | Punch Projects | \$ 7,288.29 | \$ 7,288.29 | 7,288.29 | |
| Cle Elum | Washington State Horse Park | \$ 7,496.53 | \$ 7,496.53 | 7,496.53 | |
| Ellensburg | Two Little Chicks | \$ 3,123.56 | \$ 3,123.56 | 3,123.56 | |

| Fund # | Description | Appropriated | Disbursed thru 2025(PAID OUT) | Remaining |
|---------------------------|----------------------------------|--------------|----------------------------------|--------------|
| 100-165-557-32-45-000-000 | Visitor Information Center (VIC) | \$ 81,600.00 | \$ 23,921.57 | \$ 57,678.43 |
| | January | | \$ 6,994.64 | (6,994.64) |
| | February | | \$ 6,261.52 | (6,261.52) |
| | March | | \$ 3,059.48 | (3,059.48) |
| | April | | \$ 7,605.93 | (7,605.93) |
| | May | | | - |
| | June | | | - |
| | July | | | - |
| | August | | | - |
| | September | | | - |
| | October | | | - |
| | November | | | - |
| | December | | | - |

| Fund # | Description | Appropriated | Disbursed thru 2025(PAID OUT) | Remaining |
|--------------|----------------|--------------|----------------------------------|--------------|
| NEED GL CODE | Unity Park VIC | \$ 32,000.00 | \$ - | \$ 32,000.00 |
| | May | | \$ | - |
| | June | | \$ | - |
| | July | | \$ | - |
| | August | | \$ | - |
| | September | | \$ | - |

| Fund # | Description | Appropriated | Disbursed thru 2025(PAID OUT) | Remaining |
|---------------------------|---------------------|--------------|----------------------------------|-------------|
| 100-165-557-34-51-000-000 | Website Maintenance | \$ 9,000.00 | \$ - | \$ 9,000.00 |
| | January | | \$ | - |
| | February | | \$ | - |
| | March | | \$ | - |
| | April | | \$ | - |
| | May | | \$ | - |
| | June | | \$ | - |
| | July | | \$ | - |
| | August | | \$ | - |
| | September | | \$ | - |
| | October | | \$ | - |
| | November | | \$ | - |
| | December | | \$ | - |

| Fund # | Description | Appropriated | Disbursed thru 2025(PAID OUT) | Remaining |
|---------------------------|----------------------|--------------|----------------------------------|-------------|
| 100-165-557-34-51-000-001 | Collateral Materials | \$ 7,500.00 | \$ - | \$ 7,500.00 |
| | January | | \$ | - |
| | February | | \$ | - |
| | March | | \$ | - |
| | April | | \$ | - |
| | May | | \$ | - |
| | June | | \$ | - |
| | July | | \$ | - |
| | August | | \$ | - |
| | September | | \$ | - |
| | October | | \$ | - |
| | November | | \$ | - |
| | December | | \$ | - |

| Fund # | Description | Appropriated | Disbursed thru 2025(PAID OUT) | Remaining |
|---------------------------|-------------------------|---------------|----------------------------------|----------------|
| 100-165-557-33-41-000-000 | Marketing & Advertising | \$ 194,500.00 | \$ 38,962.73 | \$ 155,537.27 |
| | January | | \$ 10,497.27 | \$ (10,497.27) |

| | | | | | | | |
|----------------------------------|--|-----------|-------------------|-----------|------------------|-----------|-------------------|
| | February | \$ | 7,463.12 | \$ | (7,463.12) | | |
| | March | \$ | 7,642.33 | \$ | (7,642.33) | | |
| | April | \$ | 13,360.01 | \$ | (13,360.01) | | |
| | May | | | \$ | - | | |
| | June | | | \$ | - | | |
| | July | | | \$ | - | | |
| | August | | | \$ | - | | |
| | September | | | \$ | - | | |
| | October | | | \$ | - | | |
| | November | | | \$ | - | | |
| | December | | | \$ | - | | |
| 100-165-557-36-41-000-000 | Administration (City-Utilities) | \$ | 825.00 | \$ | 145.84 | \$ | 679.16 |
| | January | | | \$ | 31.72 | \$ | (31.72) |
| | February | | | \$ | 29.41 | \$ | (29.41) |
| | March | | | \$ | 26.56 | \$ | (26.56) |
| | April | | | \$ | 27.51 | \$ | (27.51) |
| | May | | | \$ | 30.64 | \$ | (30.64) |
| | June | | | \$ | | \$ | - |
| | July | | | \$ | | \$ | - |
| | August | | | \$ | | \$ | - |
| | September | | | \$ | | \$ | - |
| | October | | | \$ | | \$ | - |
| | November | | | \$ | | \$ | - |
| | December | | | \$ | | \$ | - |
| 100-165-557-35-35* | Signage | \$ | 10,000.00 | \$ | - | \$ | 10,000.00 |
| ST542.31247513 (Banners) | Traffic Safety Supply/Banners | | | | | | |
| 100-165-594-57-63-000-000 | Capital | | | \$ | - | \$ | - |
| Totals | | \$ | 426,020.29 | \$ | 63,030.14 | \$ | 362,990.15 |

Y:\Committees\Lodging Tax Advisory Committee\2025 LTAC\BUDGET[LODGING TAX 2025 BUDGET.xlsx]2025 Expenditures

Lodging Tax Revenues

| Tax Collected | Month Received | 2019 | 2020 | 2021 | 2022 | 2023 | 2024 | 2025 | % Diff |
|---------------------|----------------|---------------|----------------|---------------|---------------|---------------|---------------|---------------|--------------------------------|
| Nov | Jan | \$ 32,473.96 | \$ 35,253.48 | \$ 23,787.08 | \$ 36,438.78 | \$ 41,671.00 | \$ 44,806.00 | \$ 44,672.34 | 7.52% |
| Dec | Feb | \$ 26,394.00 | \$ 26,415.94 | \$ 18,709.31 | \$ 34,260.47 | \$ 29,598.00 | \$ 32,715.00 | \$ 36,727.62 | 10.53% |
| Jan | Mar | \$ 28,172.00 | \$ 24,341.00 | \$ 22,227.38 | \$ 28,797.14 | \$ 26,580.00 | \$ 36,255.00 | \$ 29,793.00 | 36.40% |
| Feb | Apr | \$ 28,704.00 | \$ 21,564.30 | \$ 25,123.77 | \$ 32,367.49 | \$ 32,185.00 | \$ 46,772.82 | \$ 38,728.00 | 45.32% |
| Mar | May | \$ 42,825.04 | \$ 14,989.00 | \$ 33,426.21 | \$ 42,788.39 | \$ 63,391.00 | \$ 56,785.00 | | -10.42% |
| Apr | June | \$ 48,351.36 | \$ 8,641.32 | \$ 39,290.38 | \$ 50,226.13 | \$ 58,094.00 | \$ 69,805.00 | | 20.16% |
| May | July | \$ 56,037.14 | \$ 36,383.12 | \$ 45,224.41 | \$ 73,668.73 | \$ 78,934.00 | \$ 90,411.00 | | 14.54% |
| June | Aug | \$ 72,925.97 | \$ 32,565.00 | \$ 55,965.00 | \$ 74,578.90 | \$ 93,622.87 | \$ 93,089.00 | | -0.57% |
| July | Sept | \$ 67,114.33 | \$ 37,693.45 | \$ 64,746.62 | \$ 81,366.91 | \$ 92,595.00 | \$ 93,957.00 | | 1.47% |
| Aug | Oct | \$ 72,295.90 | \$ 39,967.63 | \$ 67,762.40 | \$ 77,160.00 | \$ 80,540.00 | \$ 100,833.00 | | 25.20% |
| Sept | Nov | \$ 55,515.88 | \$ 41,344.25 | \$ 69,683.38 | \$ 79,311.00 | \$ 81,098.00 | \$ 94,898.00 | | 17.02% |
| Oct | Dec | \$ 47,206.56 | \$ 34,286.22 | \$ 51,283.92 | \$ 64,062.00 | \$ 72,427.00 | | | -100.00% |
| Nov | Jan | | | | | | | | 2024.00% |
| TOTAL | | \$ 578,016.14 | \$ 353,444.71 | \$ 517,229.86 | \$ 675,025.94 | \$ 750,735.87 | \$ 760,326.82 | \$ 149,920.96 | \$ 605,797.00 5 year average |
| | | | | | | | | | \$ 687,000.00 Budgeted Revenue |
| % Difference | | 9.03% | -38.85% | 46.34% | 30.51% | 11.22% | 1.28% | | |
| | | 578,016 | 353,445 | 517,230 | 675,026 | 750,736 | 760,327 | | |

2025 EXPENDITURES TRACKING REPORT FOR JLARC

| ELLENSBURG SPECIFIC | 2025 Estimates | | |
|------------------------------------|---------------------------|-------------------|---|
| | <i>(Not actual costs)</i> | | |
| Chamber Contract: | \$ | 324,600.00 | Approved Budgeted item (tourism contract) |
| Community Calendar: | \$ | 12,000.00 | Recommended to Council item |
| Trash Cans | \$ | 50,000.00 | Item under discussion at LTAC |
| Tourism Banner Signage Maintenance | \$ | 10,000.00 | Reoccurring budgeted item |
| 2025 Subtotal | \$ | 394,600.00 | |

| Consolidated: Ellensburg Portion | 2025 Estimates | | |
|---|-----------------------|-------------------|--|
| CLTAC Grant Administration | \$ | 7,717.00 | Item approved by CLTAC at Feb. meeting |
| Grant Pool Contribution | \$ | 97,595.00 | |
| 2025 Consolidated Subtotal: | \$ | 105,312.00 | |

2025 Estimated Total Expenditure \$ 499,912.00

2025 Beginning Fund Balance: \$1,634,549.00

2025 Estimated Ending Fund Balance: \$1,134,637.00

Kittitas County Lodging Tax Advisory Committee

205 West 5th – Suite 105
Ellensburg, WA 98926
509-962-7552 Fax 509-962-7687



April 14, 2025

Dear Members of the Consolidated Lodge Tax Advisory Committee,

The County Lodging Tax Advisory Committee appreciates the collaborative efforts made in managing and distributing lodging tax funds through the Consolidated grant application process. We are pleased to confirm our commitment to continuing with this process in 2025 for grant funding allocated for the year 2026. However, we must emphasize that our continued participation in 2026 for the funding year 2027 will be contingent upon adherence to the following requirements by all committee members:

1. Grant Application Review and Format Adjustments

- The grant application shall be reviewed, and any proposed changes to its format or hosting location/medium must be communicated to County staff no later than December of the preceding year.
- County staff will make reasonable efforts to accommodate these requests; however, any requests that exceed the capacity of the County IT Department may be deferred at staff's discretion.

2. Adherence to Grant Scoring Deadlines

- All participants in the Lodging Tax grant process must adhere to the agreed-upon grant scoring deadlines.
- Failure to meet these deadlines will result in the forfeiture of the participant's ability to score the applications relevant to that grant cycle and participate in the presentation meeting and voting process.

3. Review and Discussion of Scoring Consolidation Procedures

- We request a meeting to review and discuss the procedures and format for scoring consolidation to ensure clarity and uniformity among all participants.

4. Administrative Cost Sharing Agreement

- All participating entities agree to share administrative costs in an amount proportional to their overall contribution to the Consolidated Lodging Tax Pool.

We believe these measures will enhance efficiency, fairness, and accountability within the grant application process. We look forward to continued collaboration with Roslyn, Cle Elum, Ellensburg, and the County Lodging Tax Advisory Committee to ensure the effective use of lodging tax funds.

Sincerely,

A handwritten signature in blue ink, appearing to read 'Laura Osiadacz', with a stylized, cursive script.

Laura Osiadacz, Chair, County Commissioner

Jessica Karraker
Lower County Entity that pays into the fund

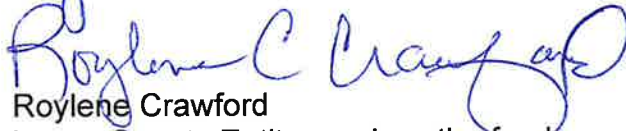
A handwritten signature in blue ink that reads 'Jessica Karraker' in a cursive script.A handwritten signature in blue ink that reads 'Roylene Crawford' in a cursive script.

Roylene Crawford
Lower County Entity receives the funds

Victor Woodward
Upper County Entity receives the funds

A handwritten signature in blue ink that reads 'Victor Woodward' in a cursive script.

Karen Porter
Upper County Entity that pays into the fund
approved via WebEX



STAFF REPORT: June 4, 2025

REPLACEMENT TRASH CAN DISCUSSION

Prepared by: Kelle Vandenberg for Lodging Tax Advisory Committee

DISCUSSION:

The City Parks & Recreation and Public Works staff researched several options for replacement trash cans in the downtown. We currently have 48 trash cans, however as our downtown is expanding and we see an increase in visitors, EDA and City are discussing adding additional bin options for waste management.

Selection options reviewed were chosen for simplicity of maintenance, longevity, attractiveness, and ability to compliment other beautification features within the downtown area.

QUESTIONS FROM LTAC May 2025 Meeting:

1. What does it currently cost to have Parks and Recreation water the nodes downtown?

\$22,000.00

City currently pays temporary/seasonal employee five days a week for approximately 20 weeks (mid-May through mid-September) watering downtown nodes, planters, and trees.

2. What would it cost to have a landscaping company water the downtown planters, nodes, and trees?

Uncertain, however because of union issues associated with contract out this service, the City has not pursued this option. City staff estimates that it will be more expensive, as we currently only pay for staff time and taxes, utilizing City-owned equipment. If we contracted out, we would pay for wages, equipment, insurance, taxes, and water usage.

Previously, the EDA held the responsibility for watering the planters, however the subcontractor who had the watering truck, opted not to repair the truck and discontinued the service.

3. What did LTAC pay for the trash receptacles in the past and what was the total cost of them?

In 2013, LTAC authorized up to \$80,000.00 in funding to the EDA and reimbursed \$71,036.00 to the EDA to purchase the existing trash cans. Individual can cost: \$1,479.91. The existing cans are approximately 11-12 years old.

RECOMMENDED OPTIONS FOR REPLACEMENT

There are three options under consideration. Factors that will determine the final selection:

1. Durability
2. User functionality
3. Attractiveness

With all three options below, quantity discounts are available, but not reflected in the pricing below.

OPTION A:

[Commercial Steel Waste Receptacles WR-122 - - Barco Products](#)

Commercial Steel Waste Receptacles

★★★★☆ 4 | 1 Review

As low as
\$599.00 Quantity discounts available

SKU WR-122

| Quantity Discounts | | |
|--------------------|----------|----------|
| Quantity | 3 | 6 |
| Price | \$585.00 | \$565.00 |

Product Configuration

Lid Type

Qty:

[Email a link to this product](#)

Specifications

| SKU | 08JB3047 | 08JB3048 |
|---------------------------|----------------------------|-----------------------------------|
| Model Name | 32 Gal Flat Lid Receptacle | 32 Gal Rain Bonnet Lid Receptacle |
| Material | Steel | Steel |
| Overall Dimensions | 27.5"Dia. x 35.5"H | 27.5"Dia. x 44"H |
| Weight | 75.0 | 79.0 |

Description

Great value for popular style trash can

- Durable, steel trash can is ideal for office parks, towns, colleges, and more
- Classic, functional design with spacious interior
- Heavy-duty slats reinforced with fully welded circular bands and Black powder-coated finish
- Long-lasting and weatherproof
- Vandal- and graffiti-resistant
- Includes rigid 32-gallon liner with choice of rain bonnet or flat lid, both with 10" dia. top opening
- Fasten lid to receptacle with included security cable
- Pre-drilled for surface mount

48 cans \$28,800.00

55 cans \$33,000.00

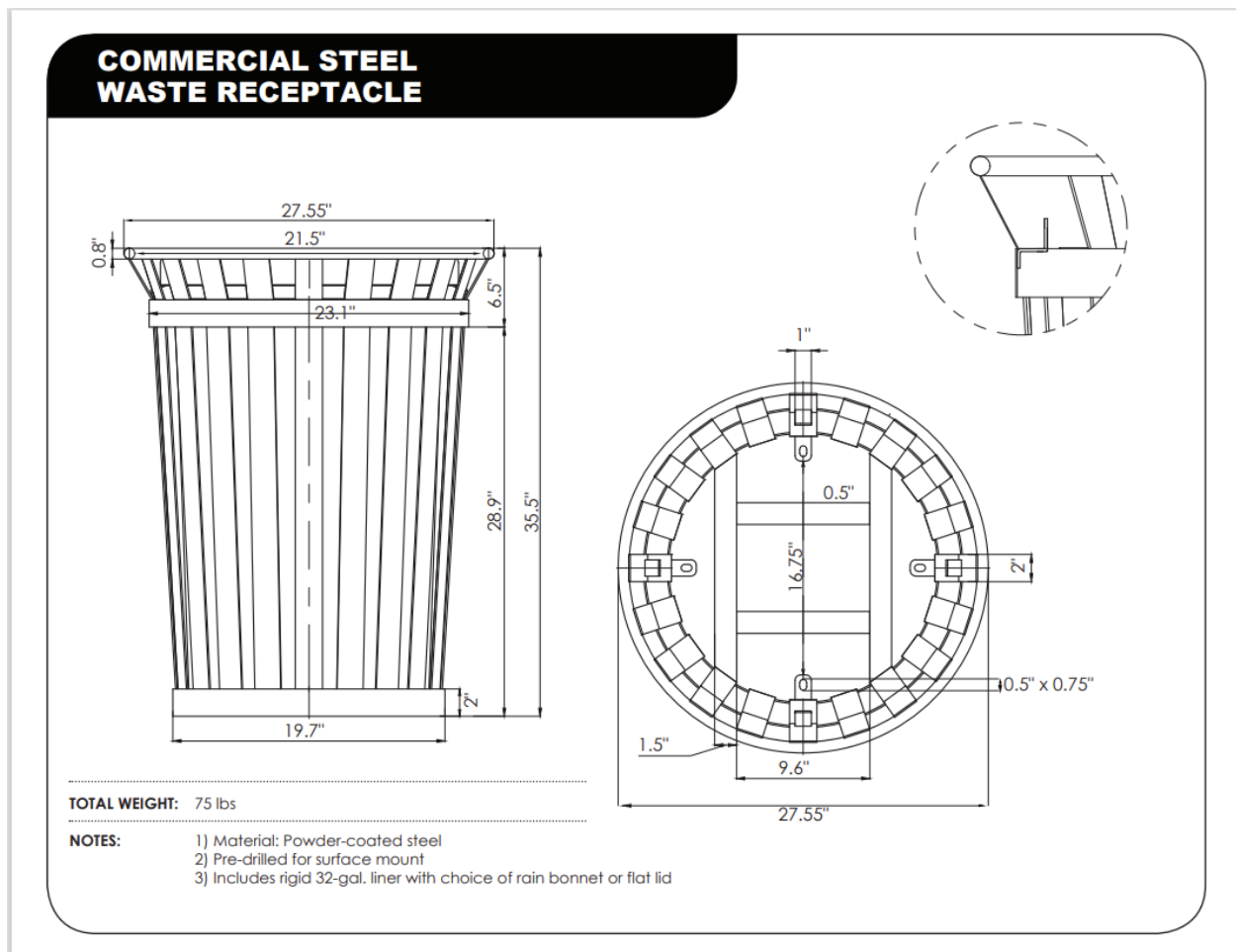

OPTION B:

[All Steel 30-Gallon Receptacle 08AM1588 - Steel 30 gal receptacle - Barco Products](#)

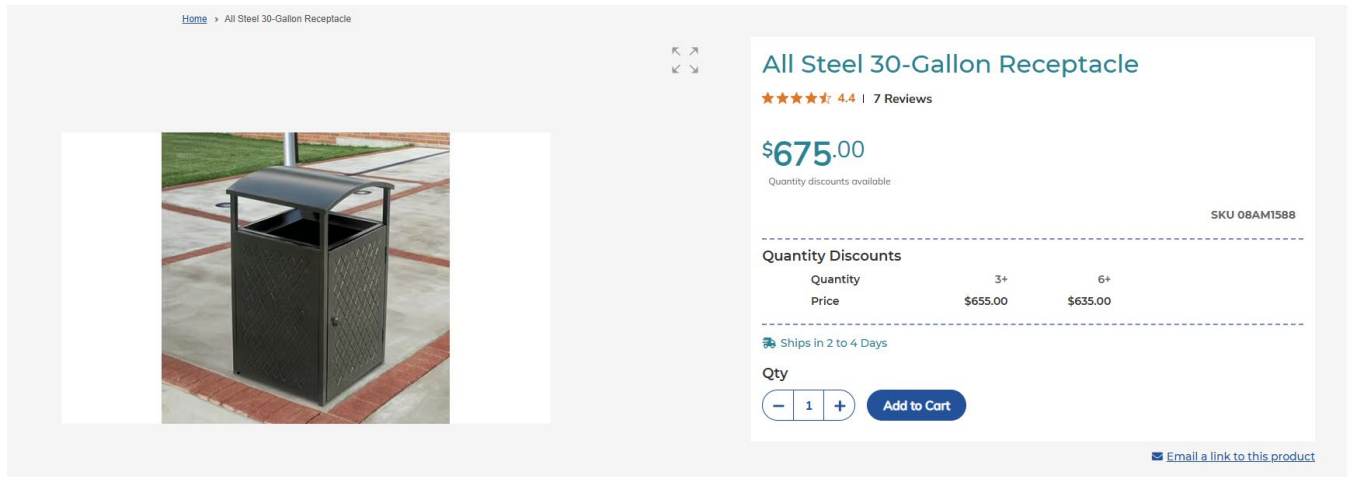

The screenshot shows a product page for the 'All Steel 30-Gallon Receptacle'. On the left is a photograph of a dark-colored, rectangular trash can with a rain bonnet on top and a side door. On the right, the product title is 'All Steel 30-Gallon Receptacle' with a 4.4 star rating and 7 reviews. The price is listed as \$675.00. Below the price is a table for quantity discounts:

| Quantity | 3+ | 6+ |
|----------|----------|----------|
| Price | \$655.00 | \$635.00 |

The page also includes an 'Add to Cart' button and a link to email a link to the product.

Specifications

| | |
|---------------------------|-------------------|
| SKU | 08AM1588 |
| Model Name | 30 gal receptacle |
| Material | Steel |
| Capacity | 30 Gallon |
| Overall Dimensions | 20" Sq. x 34"H |
| Weight | 53.0 |

Description

Durable Bronze powder-coated steel construction is rust-resistant.

- Unique and attractive design
- Generous 13.5" sq. top opening with rain bonnet
- Free 30-gallon capacity metal liner
- Convenient side door for waste removal
- Durable weather-resistant powder-coated finish
- Shipped knocked down for savings on shipping costs
- Capacity: 30-gal.
- Material: Steel
- Finish: Powder-coated
- Permanently affixed rain bonnet lid & metal liner included

48 cans \$32,400.00

55 cans \$37,125.00

30 GALLON ALL STEEL RECEPTACLE SPECIFICATIONS

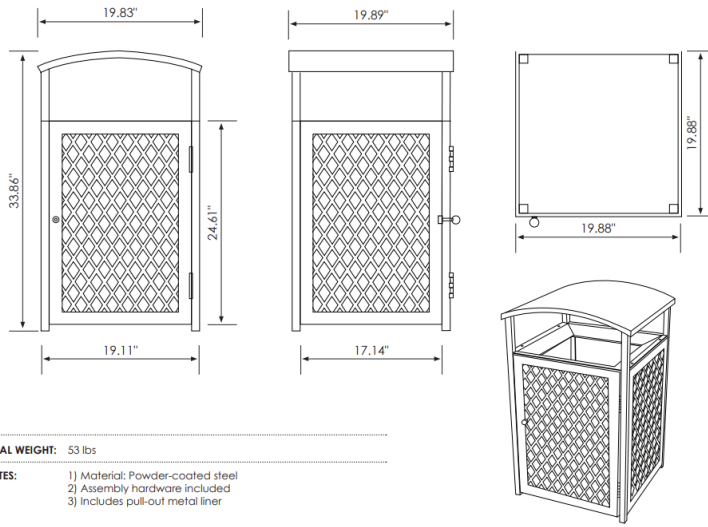

TOTAL WEIGHT: 53 lbs

- NOTES:
- 1) Material: Powder-coated steel
 - 2) Assembly hardware included
 - 3) Includes pull-out metal liner

OPTION C:

<https://www.officedepot.com/a/products/5397495/Alpine-All-Weather-40-Gallon-Outdoor/>

Alpine All-Weather 40-Gallon Outdoor Commercial Trash Can, With Lid, Silver

★★★★★ 5.0 (38)



\$751.99/each

1

As low as \$40.51/mo with **PayPal**. [Learn more](#)

[Wish lists](#)

[Shopping lists](#)

Also available in

Select An Option

Delivery

Estimated delivery 3-5 business days

99+ In Stock

Description

Diverse Supplier

The Alpine Industries Rugged 40 Gal. All-Weather Trash Containers are the perfect solution to keeping your high traffic areas tidy at picnic grounds, food courts, ballparks, outdoor dining areas any indoor or outdoor venue where food or beverages are served. Water-shedding, domed, lockable lid has generous openings on all 4 sides to receive refuse from any direction. Equipped with a piano hinge and dual chain retainers for secure support, the lid opens wide, giving easy access to quickly remove and replace trash bags from the separate, leak-proof, washable liner.

- Framing and lid fabricated of weather-resistant powder-coated steel for long-life.
- Perforated galvanized steel.
- Rugged, leak-proof plastic insert bin securely supports trash bags.
- 40 Gal. capacity extends time between collections.
- lockable lid with 4 side openings.
- 61 lbs, and can anchor trash can to the ground.
- Backed by the manufacturer's 1-year limited warranty.

Specs



Product Specifications

| | |
|------------------|--|
| Item # | 5397495 |
| Manufacturer # | 471-40-SIL |
| Color | Silver |
| Depth | 21-1/16 in. |
| Height | 41-3/8 in. |
| Width | 21-1/16 in. |
| Capacity | 40 gal |
| Fire Resistant | Yes |
| Lid Included | Yes |
| Liners Included | Yes |
| Lockable | Yes |
| Primary Material | Steel |
| Rolling | No |
| Shape | Rectangle |
| Brand Name | Alpine |
| Dimensions | 41-3/8 in. X 21-1/16 in. X 21-1/16 in. |
| Diverse Supplier | Minority-Owned Business; Disability-Owned Business; Veteran-Owned Business; Service-Disabled Veteran Owned Business; Small Business; LGBT-Owned Business |
| Manufacturer | ADIR CORP. |

48 CANS: \$36,096.00

55 CANS: \$41,360.00